

# Pi-Vac Elaste System®

The Pi-Vac Elaste System® consists in packaging pre-rigor muscles in highly elastic film tubes.

Each film tube is stretched to enable the introduction of a meat piece. Once the meat is inside, the film is released and returns to its original dimensions.

As a result the tubes exert strong forces on muscles, hindering radial expansion caused by muscle fibre contraction during *rigor mortis* development.

This system improves meat aspect and tenderness and reduces packaging costs.

Developed by:



Involved in the project:



and



## Contacts:

- **Pi-Patente GmbH**  
Entwicklung und Verwertung  
Rodheimer Str. 6  
35435 Wettenberg, GERMANY  
  
**Hans-Werner Meixner**, CEO  
[pipatente@aol.com](mailto:pipatente@aol.com)
- **NOFIMA MAT**  
Osloveien 1  
N-1430AS, NORWAY  
  
**Bjorg Narum**, Adviser/Food technologist  
[bjorg.narum@matforsk.no](mailto:bjorg.narum@matforsk.no)
- **ADIV**  
10 rue Jacqueline Auriol  
ZAC des Gravanches  
63 039 Clermont-Ferrand Cedex 2, FRANCE  
  
**Laurent Picgirard**, Products and processes technologies,  
Meat and products transformation  
[laurent.picgirard@adiv.fr](mailto:laurent.picgirard@adiv.fr)
- **IRTA**  
Meat Technology Center  
Granja Camps i Armet  
17121 Monells(Girona), SPAIN  
  
**Carolina Realini**, Meat and Carcass Quality Unit  
[carolina.realini@irta.es](mailto:carolina.realini@irta.es)

ADIV 2009 © all rights reserved



# Pi-Vac Elaste System®

The Pi-Vac Elaste System® consists in packaging pre-rigor muscles in highly elastic film tubes.



This technology has been demonstrated in the framework of the ProSafeBeef project (FOOD-CT-2006-36241, Integrated Project in FP6 ) on 18<sup>th</sup> June 2008 at Nortura, Rudshogda, Norway. The following information was provided by Pi-Patente, the Pi-Vac Elasto Pack® manufacturer, and Nortura, a company which has implemented this process.

## Use of the system

1. Plastic film tube preparation: the film is placed on the packaging chamber's hooks.
2. Air removal inside the packaging chamber ( see picture below ): the hooks stretch the film and the air is removed from the packaging chamber dilating the plastic film tube.
3. Meat piece introduction ( see picture below ).
4. Pressure release around the plastic film tube: the plastic film tube returns to its original dimensions, the meat piece is packed.
5. Packed meat piece extraction.
6. Plastic film tube removal: the plastic film tube is easily cut using the pre-cut end.



Air removal inside the packaging chamber



Meat piece introduction



Packaging chambers

## Figures

Pack-Man-System	
Description	Price
Packaging machine I 2,0 – 2,5 – 3,0	38.517,00 €
Packaging machine II 2,5 – 3,5 – T	32.922,00 €
Automatic in feed belt for meat	6.413,00 €
Clipping machine	3.969,00 €
Complete packaging system	81.821,00 €

Pack-Man-System indicative prices (2007)

	Shrinking bags	Pi-Vac Elasto Pack®
Price for 1 m <sup>2</sup> without quantity discount	1.43 €	2.70 €
Price for 1 m <sup>2</sup> with quantity discount	0.99 €	1.86 €
Price per kg packed meat	0.10 €	0.075 €

Pi-Vac Elasto Pack indicative prices (2007)

Using the Pi-Vac Elaste System® is 25 % cheaper than using shrinking bags.

The costs saving are not based on cheap packaging materials but on the **consumption of less material** for each package!

## Benefits

1. **Place saving and costs reducing:** no cooling room and dip tank required
2. **Energy saving :** no need to cool carcasses before boning
3. **Time saving:** muscles are cooled, not whole carcasses
4. **Environmentally friendly:** less packaging materials
5. **Water retaining:** reduction of drip loss
6. **Tenderness, aspect and texture improving:** reduction of cold shortening, better shape, more juice
7. **Flavor improving:** smell and taste
8. **Shelf life extending:** longer shelf life than with vacuum packaging

## Conditions

1. Only implementable in plants where slaughtering and boning are possible
2. Adaptation of the plant's logistic to the hot boning process
3. Only for young beefs that don't require BSE test
4. More workforce than with traditional processes (wrapping and packaging in one work cycle plus controlling and sorting the meat pieces )

## Diagram of a packaging chamber

Start position

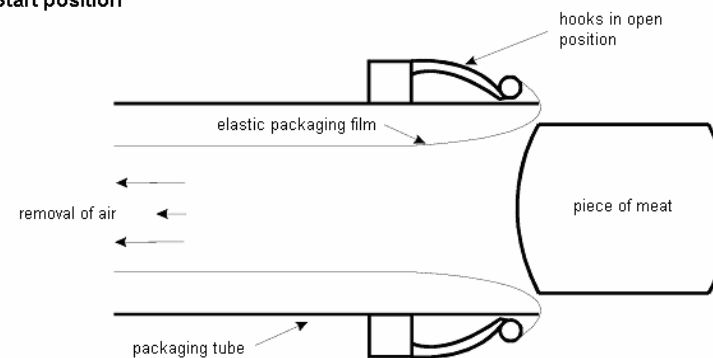

End position

